



M600
NUTS ROASTING MACHINE

COMPANY BİOGRAPHY



Our company "Gulmak Machine" offers products and services in accordance with the highest quality standards. We maintain a high level of satisfaction for our customers, employees and suppliers. In this direction, our main goal is to be a company that is sensitive to the needs of society and the environment, which prefers reliability and affordability for those who choose Gulmak Machine. Gulmak Machine manufactures and distributes coffee roasting machines, nut roasting machines, dragee chocolate coating machines and nut sugar caramelizing machines. We sell our machines all over the world, while constantly developing and following new trends in the production of equipment for coffee and nuts.

NUTS ROASTING MACHINE M600



GENERAL INFORMATION



Capacity	15-25 Kg / per hour
Working electrical voltages	3×380 Volt /50-60 Hz. 3x220 Volt /50-60 Hz.
Max. Electrical power	3×380 Volt /50-60 Hz. Max. 9 Kw-16 A 3x220 Volt /50-60 Hz. Max. 9 Kw-32 A
Roasting type	DRY AIR
Working System	Electricity
Electrical Equipment	Siemens
Roast memorization	Storing up to 25 parameters
Heat indicator	PLC Touch control panel
Lighting	12 Volt – Led Lighting
Salt Sieve/ Salt pan	1 pc./ 1 pc.
Material	100% Stainless Steel AISI 304
Roasting room lighting	1 pc. 300 Degrees heat bulb
Cooling glass cover	2 pcs.
Wide conveyor belt	50 cm
Safety	Heater electric current sensor



800 Dr. Insulation



Double insulating glass

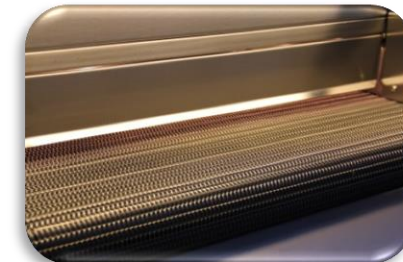

AISI 304 stainless steel band

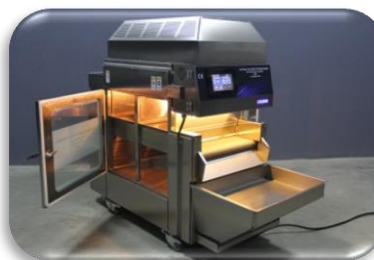

Fast cooling



Easy cleaning



Ergonomic use

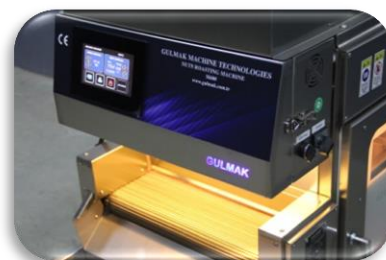

Touch control panel



AISI 304 stainless steel



Fuel saving with turbo system

ROASTING CAPACITY

PRODUCT	CAPACITY/ PER HOUR
SUNFLOWER SEEDS	14 KG
SUNFLOWER (WHITE)	12 KG
PISTACHIO IN SHELL	18 KG
PISTACHIO	19 KG
ALMOND	19 KG
HAZELNUT	26 KG
PEANUT	20 KG
PUMPKIN SEEDS	16 KG
PEANUTS IN SHELL	10 KG
CASHEW	20 KG

These Values are Given as Average.



DIMENSIONS



MACHINE DIMENSIONS

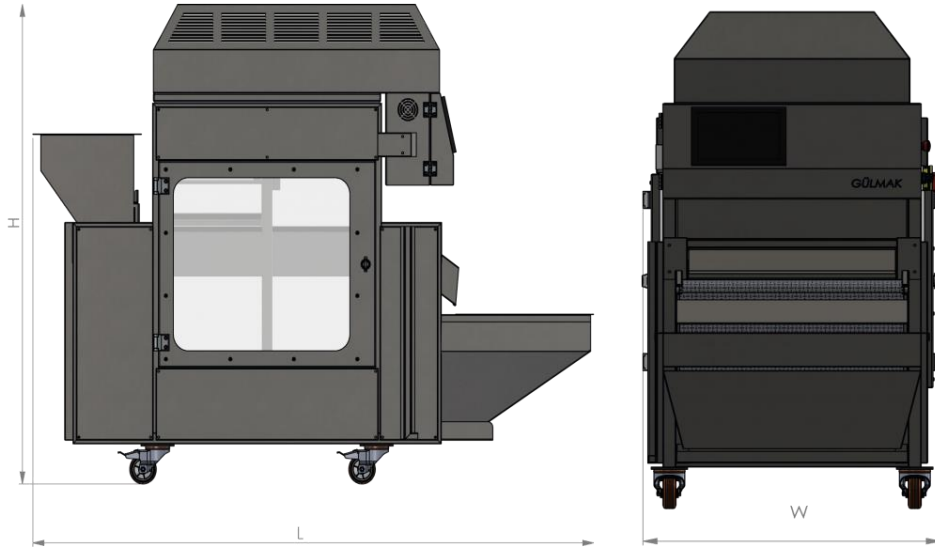

H	L	W	WEIGHT
1300 MM	1700 MM	800 MM	215 KG

SHIPPING DIMENSIONS



H	L	W	WEIGHT
1550 MM	1600 MM	850 MM	286 KG

ADDITIONAL EQUIPMENT



TM15
Nuts salting machine



TM 5
Nuts salting machine



MX 100
Nut salting liquid mixer

ONLINE SUPPORT



+90 532 368 2154

English – Russian – Turkish – Arabic client advisors

WARRANTY

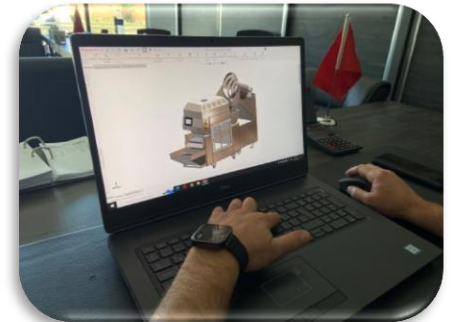

Electrical warranty (Siemens): 12 month
Mechanical warranty: 24 month

EXPORT



SOME OF REFERENCE



CONTACT INFORMATION



+90 532 368 2154



+90 236 816 3822



info@gulmak.com.tr

sales@gulmak.com.tr



Seyitali Mah. 219 Sk. No:29 Kula / MANİSA / TURKEY



[gulmak machines](#)



[gulmak machines](#)



[gulmak machines](#)



[gulmak machines](#)