



**M600**  
**KURUYEMİŞ KAVURMA MAKİNASI**

# ŞİRKET BİYOGRAFİSİ



GÜLMAK 1990 Yılında Kula/Manisa'da Kahve, kuruyemiş Ve Draje Çikolata Kaplama Makinaları Üzerine Çalışmalarına Başlamıştır.

Her Geçen Gün Kendini Yenileyip, Kullanıcı İle Makina Arasındaki Hassas Yolun Temelini Oluşturmuştur.

Kahve İle Beraber Kuruyemiş Ürünlerinin Hassas Kavurulması, Homojen Olarak Draje Kaplanmasında Tecrümelerimizle Beraber Siz Değerli Müşterilerimize Hizmet Vermenin Gururunu Yaşamaktayız.

GÜLMAK Ailesi Olarak Tecrübeli Ve Deneyim Sahibi Çalışanları, Bilgi Birikimi Ve Modern İş Hayatı İlkelerine Uygun Prensipleriyle kalite, Güvenirlik Ve Müşteri Memnuniyetini Ön Planda Tutarak Hizmetlerini Sürdürmektedir.

# KURUYEMİŐ KAVURMA MAKİNASI M600



# GENEL ÖZELLİKLER



Genel Kapasite	15-25 Kg Kuruyemiş Ürünleri / Saat
Çalıştığı Elektrik Voltajları	3×380 Volt /50-60 Hz. 3×220 Volt /50-60 Hz.
Max. Elektrik Gücü	3×380 Volt /50-60 Hz. Max. 9 Kw-16 A; 3×220 Volt /50-60 Hz. Max. 9 Kw-32 A;
Gövde	%100 AISI 304 Paslanmaz çelik
Kavurma Tipi	Kuru Hava
Kontrol	Dokunmatik Kontrol Paneli
Ürün Reçete	25 Ürün Parametre Saklama Sayfası
Aydınlatma	12 Volt – Led Aydınlatma
Tuz Eleği/ Tuz Tavası	1 Adet/ 1 Adet
Elektrik Donanımları	Siemens
Kavurma Odası Aydınlatma	1 Adet 300 Dr. Isı Ampul
Soğutma Cam Kapak	2 Adet
Emniyet	Isıtıcı Akım Rolesi
Kavurma Bandı	50 cm



**800 Dr. İzolasyon**



**Çift Isıcam**

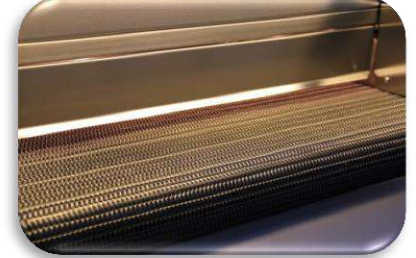

**AISI 304 Kalite Paslanmaz Bant**



**Hızlı Soğutma**



**Kolay Temizleme**



**Ergonomik Kullanım**



**Dokunmatik Kontrol Paneli**



**AISI 304 Kalite Paslanmaz Çelik Gövde**



**TURBO'lu Sistem Yakıt Tasarrufu**

# KAVURMA KAPASİTESİ

ÜRÜN	KAPASİTE / SAAT
AYÇEKİRDEĞİ	14 KG
AYÇEKİRDEĞİ (BEYAZ)	12 KG
ANTEP FISTIĞI	18 KG
ANTEP İÇİ	19 KG
BADEM	19 KG
FINDIK	26 KG
FISTIK	20 KG
KABAK ÇEKİRDEĞİ	16 KG
KABUKLU YER FISTIĞI	10 KG
KAJU	20 KG

Bu Değerler Ortalama Olarak Verilmiştir.  
Bulunduğu Ortama, Ürünün Tanesel Hacmine,  
Ortamdaki İle Beraber Üründeki Neme Göre  
Değişiklik Gösterebilir.



# ÖLÇÜLER



## MAKİNA ÖLÇÜLERİ

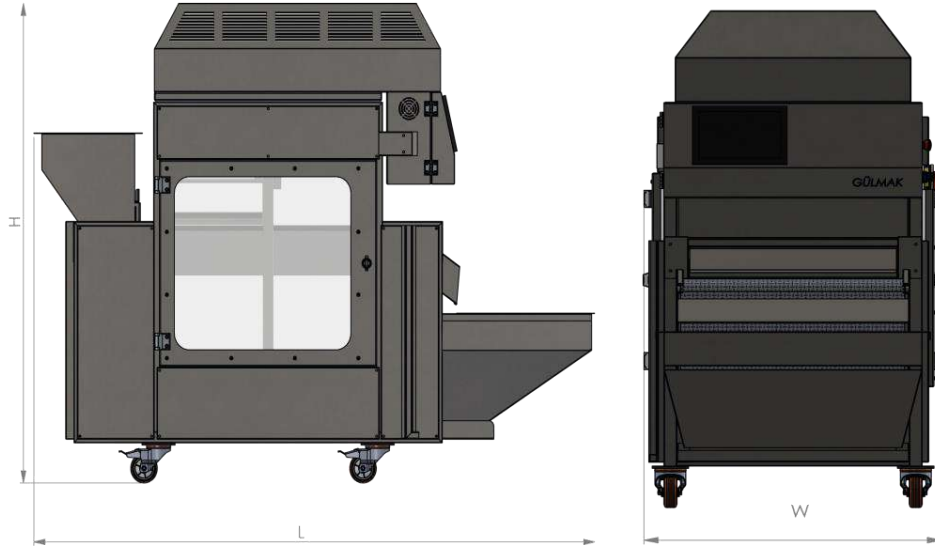

Yükseklik H	Boy L	En W	AĞIRLIK
1300 MM	1700 MM	800 MM	215 KG

## NET ÖLÇÜLER

## NAKLIYE TAŞIMA ÖLÇÜLERİ



Yükseklik H	Boy L	En W	AĞIRLIK
1500 MM	1800 MM	900 MM	286 KG

## BRÜT ÖLÇÜLER

# ONLINE DESTEK



+90 532 368 2154

İngilizce – Rusça – Türkçe – Arapça Müşteri Danışmanları

# GARANTİ

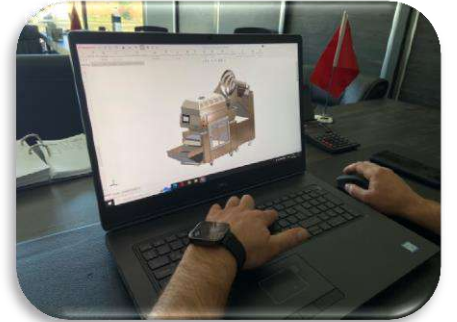

Elektrik garantisi (Siemens): 12 ay  
Mekanik garantisi: 24 ay

# İHRACAT



# BAZI REFERANSLARIMIZ



Roundore



Otto  
NUTS



Milhans  
Milhans Gıda ve Tarım Ürünleri San. ve Tic. A.Ş.



papagan



# İLETİŞİM BİLGİLERİ



+90 532 368 2154



+90 236 816 3822



[info@gulmak.com.tr](mailto:info@gulmak.com.tr)

[sales@gulmak.com.tr](mailto:sales@gulmak.com.tr)



Seyitali Mah. 219 Sk. No:29 Kula / MANİSA / TURKEY



[gulmak machines](#)



[gulmak machines](#)



[gulmak machines](#)



[gulmak machines](#)