



**NOVA 12**  
**KAHVE KAVURMA MAKİNASI**

# ŞİRKET BİYOGRAFİSİ



GÜLMAK 1990 Yılında Kula/Manisa'da Kahve, kuruyemiş Ve Draje Çikolata Kaplama Makinaları Üzerine Çalışmalarına Başlamıştır.

Her Geçen Gün Kendini Yenileyip, Kullanıcı İle Makina Arasındaki Hassas Yolun Temelini Oluşturmuştur.

Kahve İle Beraber Kuruyemiş Ürünlerinin Hassas Kavurulması, Homojen Olarak Draje Kaplanmasında Tecrümelerimizle Beraber Siz Değerli Müşterilerimize Hizmet Vermenin Gururunu Yaşamaktayız.

GÜLMAK Ailesi Olarak Tecrübeli Ve Deneyim Sahibi Çalışanları, Bilgi Birikimi Ve Modern İş Hayatı İlkelerine Uygun Prensipleriyle kalite, Güvenirlik Ve Müşteri Memnuniyetini Ön Planda Tutarak Hizmetlerini Sürdürmektedir.

# KAHVE KAVURMA MAKİNASI NOVA 12



# GENEL ÖZELLİKLER



|                            |   |
|----------------------------|---|
| <b>Tambur Kapasitesi</b>   | <b>12 Kg</b>  |
| Tambur Çalışma Oranı       | 3/1   |
| Saatlik Üretim Kapasitesi  | 48-60 Kg / Saat   |
| Kavurma Süresi             | 12-15 Dk.   |
| Kavurma Tipi               | Termal  |
| Çalıştığı Elektrik Gücü    | 1x220 / 3x220 / 3x380 Volt 50-60 Hz.                        |
| Max. Elektrik Harcama Gücü | 1.1 KW  |
| Çalışabildiği Yakıt Türü   | DoğalGaz / LPG / Propan                                     |
| Kontrol                    | Dokunmatik Kontrol Panel                                    |
| Kavurma Profil             | 15 Kavurma Profili Saklama Sayfası                          |
| Aydınlatma                 | 12 Volt – Led Aydınlatma Lambası                            |
| Cidar                      | Çift Cidar 800° İzolasyon                                   |
| Motor Sayısı               | 4 Adet  |
| Emniyet                    | Isı Algılayıcı Brülör Sensörü<br>½ Yangın Söndürme Tertipli |



**Hareketli  
Control Paneli**



**Kavurma Profil  
Desteği**



**Geniş Hacimli  
Soğutma Ünitesi**



**Ergonomik  
Kullanım**



**AISI 304 Kalite  
Paslanmaz Soğutma  
Ünitesi**



**800° İzolasyon**



**3-5 Dk Arasında  
Soğutma**



**Gizli Elektrik  
Panosu**



**Tek Noktada  
Kullanım**

# PANEL ÖZELLİKLERİ

## FONKSİYON

FAN KONTROLÜ VE HIZ AYARI

TAMBUR KONTROLÜ VE HIZ AYARI

OTOMATİK SICAKLIK AYARI

BRÜLÖR KONTROLÜ VE ALEV BOYU AYARI

SOĞUTMA ÜNİTESİ MİKSERİ KONTROLÜ

KAVURMA PROFİLİ KAVURMA GRAFİĞİ

ZAMAN SAYACI

TAMBUR SICAKLIK GÖSTERGESİ

EGSOZ SICAKLIK GÖSTERGESİ



# ÖLÇÜLER

## MAKİNA ÖLÇÜLERİ

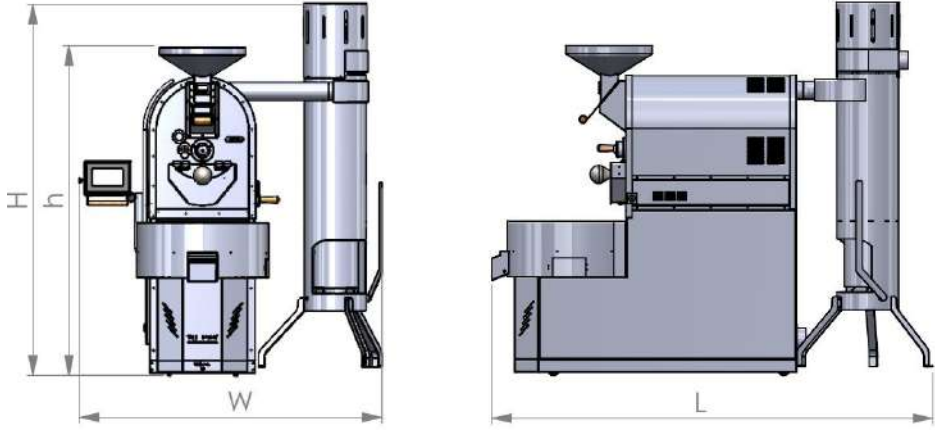

| H       | h       | W       | L       | AĞIRLIK |
|---------|---------|---------|---------|---------|
| 1800 MM | 1680 MM | 1100 MM | 2550 MM | 480 KG  |

## NET ÖLÇÜLER

## NAKLIYE TAŞIMA ÖLÇÜLERİ



| ÜRÜN                | H       | W       | L       | AĞIRLIK |
|---------------------|---------|---------|---------|---------|
| KAVURMA<br>MAKİNASI | 1700 MM | 1000 MM | 2000 MM | 530 KG  |
| KABUK SİLOSU        | 2000 MM | 650 MM  | 500 MM  | ---     |

## BRÜT ÖLÇÜLER

# ONLINE DESTEK



+90 532 368 2154

İngilizce – Rusça – Türkçe – Arapça Müşteri Danışmanları

# GARANTİ

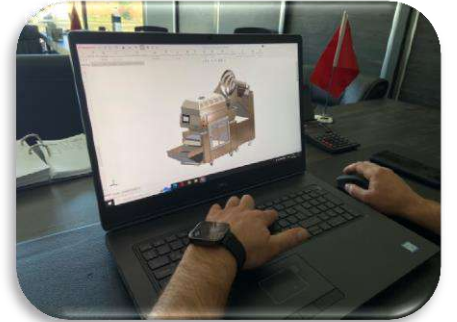
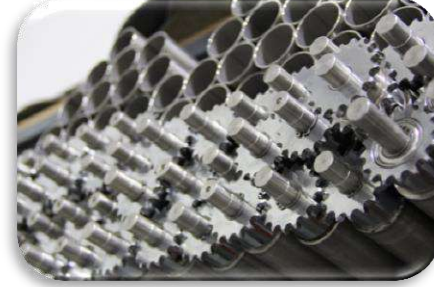

Elektrik garantisi (Siemens): 12 ay  
Mekanik garantisi: 24 ay

# İHRACAT



# BAZI REFERANSLARIMIZ



Roundore



Otto  
NUTS



Milhans  
Milhans Gıda ve Tarım Ürünleri San. ve Tic. A.Ş.



papagan



# İLETİŞİM BİLGİLERİ



+90 532 368 2154



+90 236 816 3822



[info@gulmak.com.tr](mailto:info@gulmak.com.tr)

[sales@gulmak.com.tr](mailto:sales@gulmak.com.tr)



Seyitali Mah. 219 Sk. No:29 Kula / MANİSA / TURKEY



[gulmak machines](#)



[gulmak machines](#)



[gulmak machines](#)



[gulmak machines](#)