



**NOVA 20**  
**KAHVE KAVURMA MAKİNASI**

# ŞİRKET BİYOGRAFİSİ



GÜLMAK 1990 Yılında Kula/Manisa'da Kahve, kuruyemiş Ve Draje Çikolata Kaplama Makinaları Üzerine Çalışmalarına Başlamıştır.

Her Geçen Gün Kendini Yenileyip, Kullanıcı İle Makina Arasındaki Hassas Yolun Temelini Oluşturmuştur.

Kahve İle Beraber Kuruyemiş Ürünlerinin Hassas Kavurulması, Homojen Olarak Draje Kaplanmasında Tecrümelerimizle Beraber Siz Değerli Müşterilerimize Hizmet Vermenin Gururunu Yaşamaktayız.

GÜLMAK Ailesi Olarak Tecrübeli Ve Deneyim Sahibi Çalışanları, Bilgi Birikimi Ve Modern İş Hayatı İlkelerine Uygun Prensipleriyle kalite, Güvenirlik Ve Müşteri Memnuniyetini Ön Planda Tutarak Hizmetlerini Sürdürmektedir.

# KAHVE KAVURMA MAKİNASI NOVA 20



# GENEL ÖZELLİKLER



DONANIMLAR	
Tambur Kapasitesi	20 Kg
Tambur Çalışma Oranı	3/1
Saatlik Üretim Kapasitesi	100 Kg / Saat
Kavurma Süresi	12-15 Dk.
Kavurma Tipi	Termal
Çalıştığı Elektrik Gücü	1x220 / 3x220 / 3x380 Volt 50-60 Hz.
Max. Elektrik Harcama Gücü	1.1 KW
Çalışabildiği Yakıt Türü	DoğalGaz / LPG / Propan
Kontrol	Dokunmatik Kontrol Panel
Kavurma Profil	15 Kavurma Profili Saklama Sayfası
Aydınlatma	12 Volt – Led Aydınlatma Lambası
Cidar	Çift Cidar 800° İzolasyon
Motor Sayısı	4 Adet
Emniyet	Isı Algılayıcı Brülör Sensörü ½ Yangın Söndürme Tertipli



**Hareketli  
Control Paneli**



**Kavurma Profil  
Destegi**



**Geniş Hacimli  
Soğutma Ünitesi**



**Ergonomik  
Kullanım**



**AISI 304 Kalite  
Paslanmaz Soğutma  
Ünitesi**



**800° İzolasyon**



**3-5 Dk Arasında  
Soğutma**



**Gizli Elektrik  
Panosu**



**Tek Noktada  
Kullanım**

# PANEL ÖZELLİKLERİ

## FONKSİYON

FAN KONTROLÜ VE HIZ AYARI

TAMBUR KONTROLÜ VE HIZ AYARI

OTOMATİK SICAKLIK AYARI

BRÜLÖR KONTROLÜ VE ALEV BOYU AYARI

SOĞUTMA ÜNİTESİ MİKSERİ KONTROLÜ

KAVURMA PROFİLİ KAVURMA GRAFİĞİ

ZAMAN SAYACI

TAMBUR SICAKLIK GÖSTERGESİ

EGSOZ SICAKLIK GÖSTERGESİ



# ÖLÇÜLER

## MAKİNA ÖLÇÜLERİ

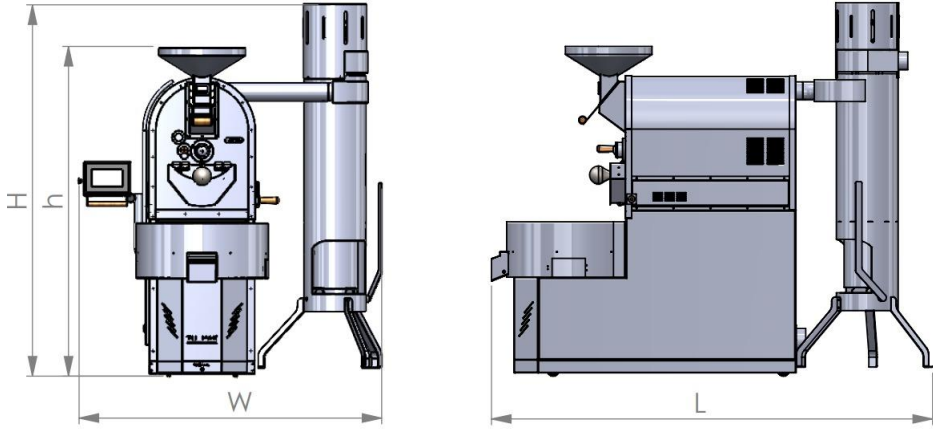

## NAKLIYE TAŞIMA ÖLÇÜLERİ



H	h	W	L	AĞIRLIK
2000 MM	1850 MM	1500 MM	2850 MM	600 KG

## NET ÖLÇÜLER

ÜRÜN	H	W	L	AĞIRLIK
KAVURMA MAKİNASI	1700 MM	1200 MM	2500 MM	650 KG
KABUK SİLOSU	2000 MM	650 MM	500 MM	---

## BRÜT ÖLÇÜLER

# OPSİYON DONANIMLAR

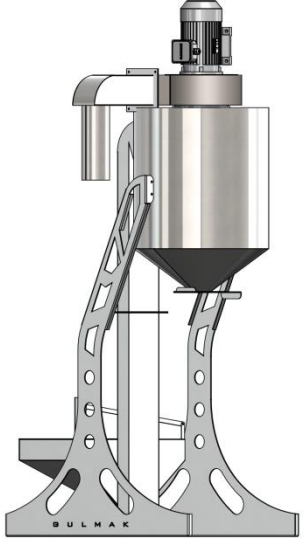

**Destoner Taş Ayırıcı**

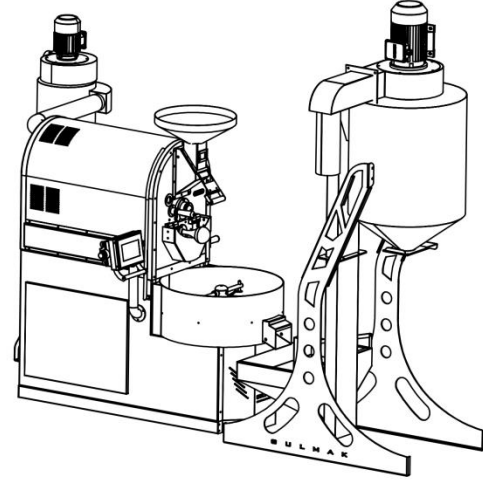

**Kahve Değirmeni**



# ONLINE DESTEK

# ZENGİN YEDEK PARÇA GARANTİ



+90 532 368 2154

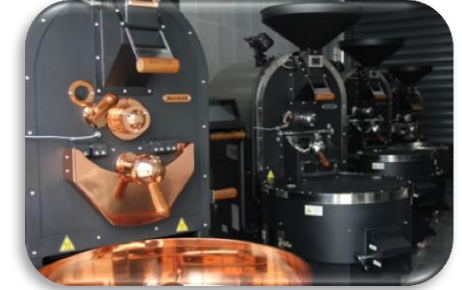

İngilizce-Rusça-Arapça Müşteri Danışmanları

ELEKTRİK GARANTİSİ: 12 AY  
MEKANİK GARANTİSİ: 24 AY



# İHRACATLARIMIZ



# BAZI REFERANSLARIMIZ



# İLETİŞİM BİLGİLERİ



+90 532 368 2154



+90 236 816 3822



info@gulmak.com.tr

sales@gulmak.com.tr



Seyitali Mah. 219 Sk. No:29 Kula / MANİSA / TÜRKİYE



gulmak machines



gulmak machines



gulmak machines



gulmak machines